

FEATURED ALUM-A-LIFT CLEANROOM LIFT WITH SWIVEL BOOM AND FIXTURE

PROJECT 31541



MODEL A800CRSLR-72

FEATURING Toolless Exchange Rotating Fixture, Swiveling Boom with Rotation Lock, Load and Obstacle Sensing, Two Handed Detachable Pendant with Active Lifting Speed Adjustment, Class 1000 (ISO 6) Cleanroom Rated, CE and SEMI Compliant

HANDLING 300 lb [136 kg] Flow Flanges

DETAILS This cleanroom system was developed for a leading semiconductor company specializing in Power, 5G RF and Photonics applications. The resulting OEM lift was designed to handle flow flanges into and out of process tools. By using a swivel boom and rotating fixture, the flow flanges could be quickly exchanged and serviced without ergonomic concerns. This greatly reduced the downtime required for maintenance.

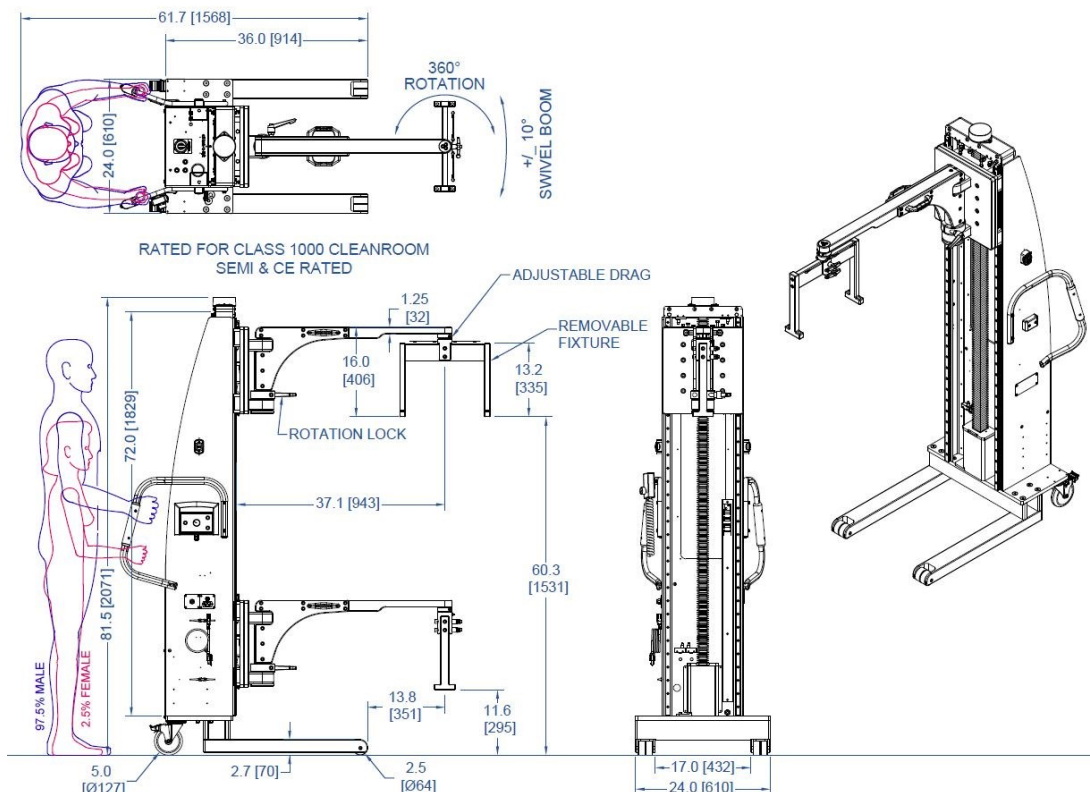

alum-a-lift

13941 Veterans Memorial Hwy
Winston, GA 30187 USA
+1 770 489 0328

GET STARTED AT ALUM-A-LIFT.COM