

FEATURED ALUM-A-LIFT INLINE ICT FIXTURE LIFT WITH POWERED ROTATION

PROJECT 30089



MODEL A800CS-72

FEATURING Rotating, Adjustable Width Fork Set, Deflection Compensation, Lifting Safety Interlock

HANDLING 250 lb [113 kg] In-Circuit Test Fixtures

DETAILS Inline ICT machines are more challenging to load and unload than their offline counterparts. This Alum-a-Lift includes extended forks that reach far into the machine and capture the ICT fixture or the corresponding exchangeable equipment. The slotted forks are compatible with “Alum-a-Grips” fixture handles and are adjustable to accommodate a range of fixture sizes. Once removed from the tester, this lifter can rotate fixtures 360 degrees for storage or for underside access.

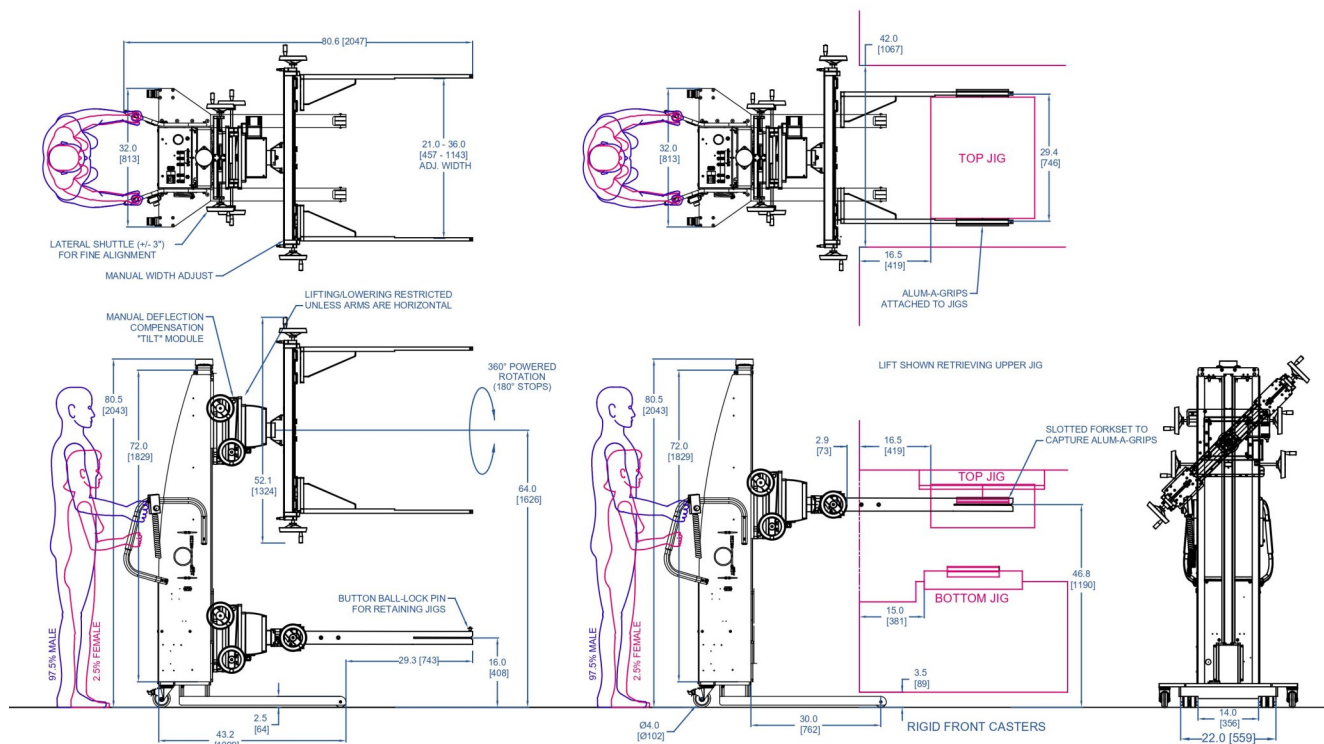

alum-a-lift

13941 Veterans Memorial Hwy
Winston, GA 30187 USA
+1 770 489 0328

GET STARTED AT ALUM-A-LIFT.COM